

# CEMPO



roof to the world abbiamo dato un tetto al mondo we have given a roof to the world abbiamo dato un tetto al mondo  
no dato un tetto al mondo we have given a roof to the world abbiamo dato un tetto al mondo we have given a  
tetto al mondo we have given a roof to the world abbiamo dato un tetto al mondo we have given a roof to the w  
o al mondo abbiamo dato un tetto al mondo we have given a roof to the world abbiamo dato un tetto al mond



**Ceipo Ceramiche has been in business for over 40 years, specialized in the production of roof tiles and varnished sunbreaks. We produce varnished single-cooked roof tiles in 220 colors, which are available in both single colored forms or in what we call "smoked" versions, where one color is mixed with another. Furthermore, our company is able to offer various types of varnish on request and tailor made for the client.**

- experience
- Quality material and products
- brand which is renown in over 30 countries worldwide.
- project and planning carefully studied together with the client.

The use of our products relays the desire to leave a sign that lasts throughout the years, a unique and attractive style which satisfies the fantasy of both companies and the private client.

- Italian quality and innovation
- 220 colors
- personalization
- collaboration
- specialization
- prestige
- exclusivity
- kindness!!!
- technology

**Ceipo Ceramiche** opera da oltre 40 anni nel campo delle terracotte, la nostra azienda produce tegole e frangisole smaltati .

Realizziamo tegole smaltate in monocottura in 220 colori, la smaltatura standard è disponibile sia in tinta unita che nella versione fiammata ( dove la base in tinta unita viene "fiammata" con un altro colore), inoltre la nostra azienda è capace di realizzare molti altri tipi di smaltature richieste dal cliente .

- esperienza
- qualità dei materiali e dei prodotti
- marchio conosciuto in oltre 30 paesi al mondo
- studio e progettazione delle soluzioni insieme al cliente

utilizzare i nostri prodotti è la volontà di lasciare un segno durevole nel tempo, uno stile unico ed attraente che soddisfa la fantasia di professionisti e privati.

- qualità e innovazione italiana
- 220 colori
- personalizzazione
- collaborazione
- specializzazione
- prestigio
- esclusività
- cordialità
- tecnologia

## CEIPO CERAMICHE





tegole e frangisole smaltati  
glazed roof tiles and sunbreaks

**CEKPO**  



GLAZED "OLANDESE"  
TYPE: T. 200 OLANDESE

Outward sizes, dimensioni esterne, dimensions	cm. 41 x 25
Quantity per sqm, quantità per mq, pieces par m2	N° 14
Weight each, peso caduno, poids	Kg. 2,650
Pieces in each box, pezzi per scatola pieces par boîte	N° 8
Pieces in each container, pezzi per container pieces par container	N° 6272



GLAZED "MARSIGLIESE"  
TYPE: T. 100 Marsigliese

Outward sizes, dimensioni esterne, dimensions	cm. 41 x 25
Quantity per sqm, quantità per mq, pieces par m2	N° 14
Weight each, peso caduno, poids	Kg. 2,750
Pieces in each box, pezzi per scatola pieces par boîte	N° 8
Pieces in each container, pezzi per container pieces par container	N° 6272



GLAZED "PORTOGHESE"  
TYPE: T. 300 Portoghese

Outward sizes, dimensioni esterne, dimensions	cm. 41 x 25
Quantity per sqm, quantità per mq, pieces par m2	N° 14
Weight each, peso caduno, poids	Kg. 2,650
Pieces in each box, pezzi per scatola pieces par boîte	N° 7
Pieces in each container, pezzi per container pieces par container	N° 5488

IL COLORE A TUA SCELTA



"HISTORICAL V"  
TYPE: HISTORICAL "V"

Outward sizes, dimensioni esterne, dimensions	cm. 20x11,5 - 22x11
Quantity per sqm, quantità per mq, pieces par m2	N° 50 - 100
Weight each, peso caduno, poids	Kg. 450 - 500
Pieces in each box, pezzi per scatola pieces par boîte	N° 52 - 38
Pieces in each container, pezzi per container pieces par container	N° 40320

GLAZED "SQUAMA Tile"  
TYPE: DOME TILE



outward sizes, dimensioni esterne, dimensions	cm 150 x 180
quantity per sqm, quantità per mq, pieces per m2	N° 37
weight each, peso ciascuno, poids	gr 640



GLAZED "SQUAMA Shingle"  
TYPE: SHINGLE

Outward sizes, dimensioni esterne, dimensions	cm. 19,6 x 15
Quantity per sqm, quantità per mq, pieces par m2	N° 77
Weight each, peso caduno, poids	Kg. 0,5

# LE NUOVE SOLUZIONI PER IL TETTO

## GLAZED "FLAT" TYPE: T. 400 Flat

Outward sizes, dimensioni esterne, dimensions	cm. 41 x 25
Quantity per sqm, quantità per mq, pieces par m2	N° 14
Weight each, peso caduno, poids	Kg. 2,700
Pieces in each box, pezzi per scatola pieces par boîte	N° 8
Pieces in each container, pezzi per container pieces par container	N° 6272

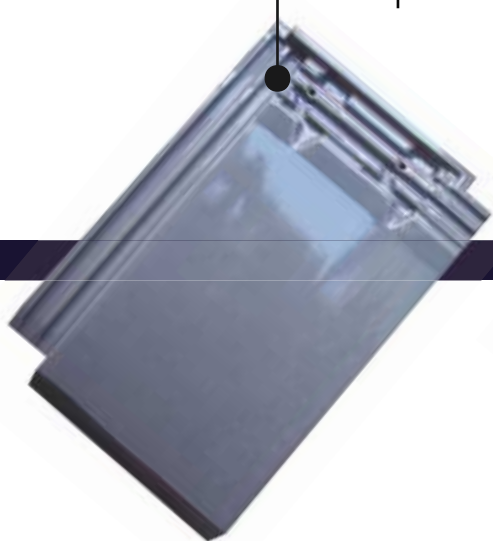

## GLAZED "COPPO" TYPE: C. 50 Coppo

Outward sizes, dimensioni esterne, dimensions	cm. 42 x 18
Quantity per sqm, quantità per mq, pieces par m2 (coppo+coppo)	N° 33
Weight each, peso caduno, poids	Kg. 2,300
Pieces in each box, pezzi per scatola pieces par boîte	N° 7
Pieces in each container, pezzi per container pieces par container	N° 5488



## GLAZED "STARLIGHT-DOUBLE COPPO" TYPE: T. 500 Starlight

Outward sizes, dimensioni esterne, dimensions	cm. 41 x 25
Quantity per sqm, quantità per mq, pieces par m2	N° 14
Weight each, peso caduno, poids	Kg. 2,650
Pieces in each box, pezzi per scatola pieces par boîte	N° 7
Pieces in each container, pezzi per container pieces par container	N° 5488



## GLAZED "ROMANA" TYPE: T. 700 Romana

Outward sizes, dimensioni esterne, dimensions	cm. 41 x 25
Quantity per sqm, quantità per mq, pieces par m2 (coppo+romana)	N° 10+10
Weight each, peso caduno, poids	Kg. 3,000
Pieces in each box, pezzi per scatola pieces par boîte	N° 7
Pieces in each container, pezzi per container pieces par container	N° 5488



## MORE THAN 200 COLOURS

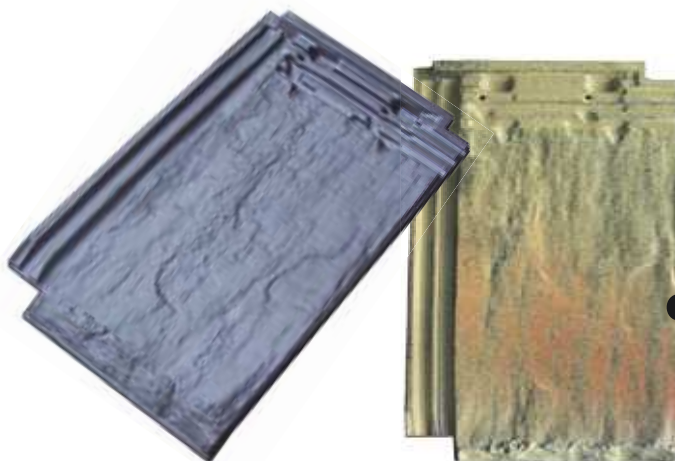

## GLAZED "FLAT SLATE" TYPE: T. 400 SLATE

Outward sizes, dimensioni esterne, dimensions	cm. 41 x 25
Quantity per sqm, quantità per mq, pieces par m2	N° 14
Weight each, peso caduno, poids	Kg. 2,700
Pieces in each box, pezzi per scatola pieces par boîte	N° 8
Pieces in each container, pezzi per container pieces par container	N° 6272









GLAZED "PORTOGHESE"  
TYPE: **T. 300** Portoghese



Outward sizes, dimensioni esterne, dimensions	cm. 41 x 25
Quantity per sqm, quantità per mq, pieces par m2	N° 14
Weight each, peso caduno, poids	Kg. 2,650
Pieces in each box, pezzi per scatola pieces par boîte	N° 7
Pieces in each container, pezzi per container pieces par container	N° 5488

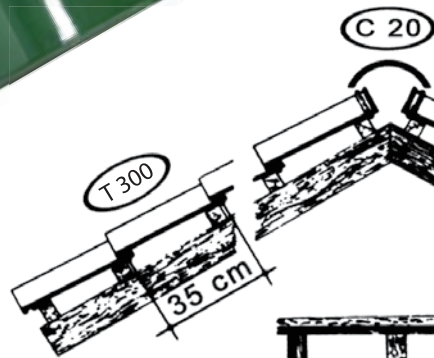

**Covering Capacity**  
approx 14 tiles per M2  
14 tegole al M2  
130 tiles per square

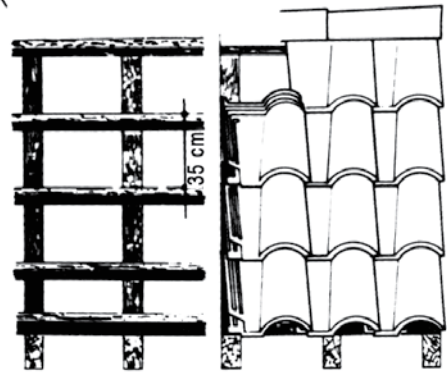

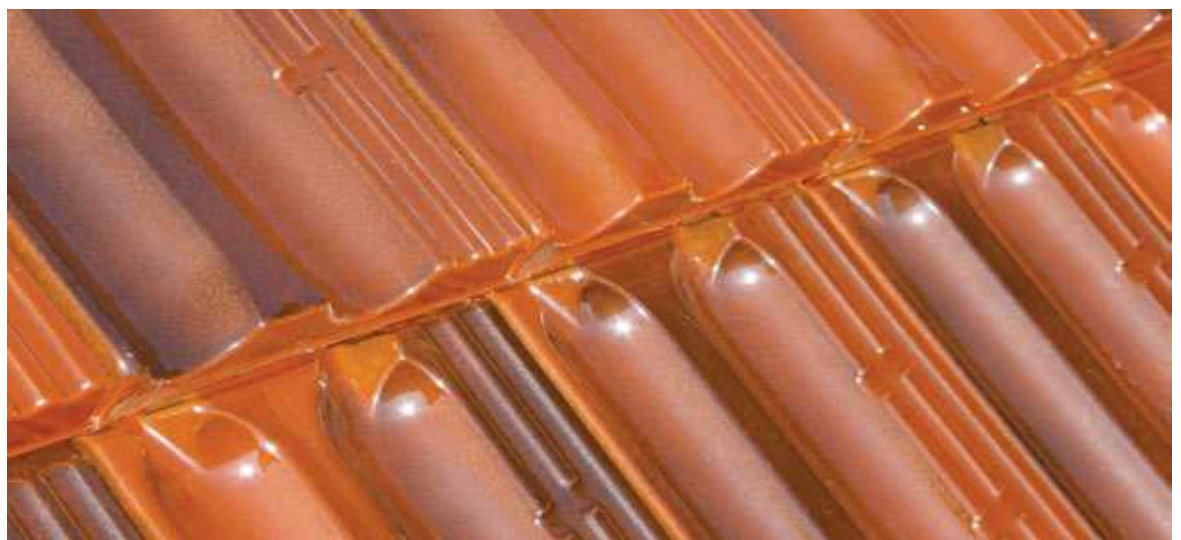



GLAZED "MARSIGLIESE"  
TYPE: **T. 100 Marsigliese**

Outward sizes, dimensioni esterne, dimensions	cm. 41 x 25
Quantity per sqm, quantità per mq, pieces par m2	N° 14
Weight each, peso caduno, poids	Kg. 2,750
Pieces in each box, pezzi per scatola pieces par boite	N° 8
Pieces in each container, pezzi per container pieces par container	N° 6272

**Covering Capacity**

approx 14 tiles per M2  
14 tegole al M2  
130 tiles per square

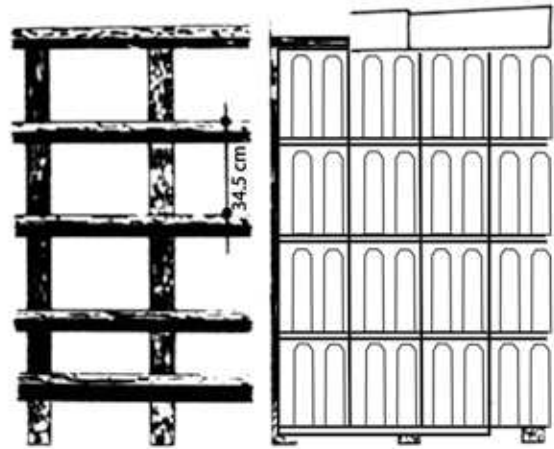
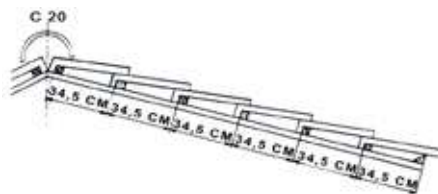

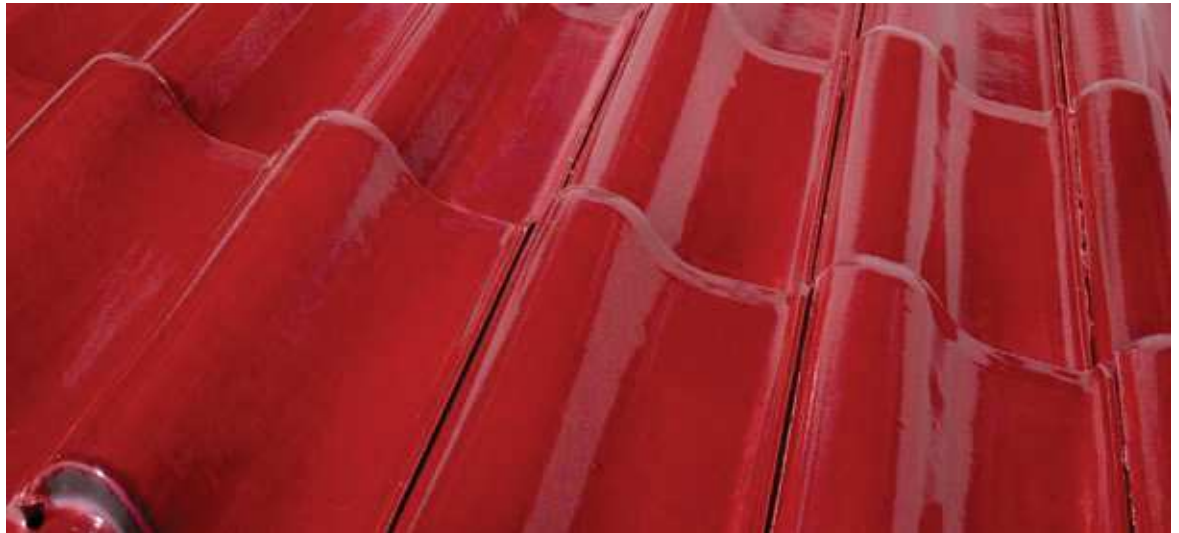



**GLAZED "OLANDESE"**  
**TYPE: T. 200 OLANDESE**

Outward sizes, dimensioni esterne, dimensions	cm. 41 x 25
Quantity per sqm, quantità per mq, pieces par m2	N° 14
Weight each, peso caduno, poids	Kg. 2,650
Pieces in each box, pezzi per scatola pieces par boîte	N° 8
Pieces in each container, pezzi per container pieces par container	N° 6272

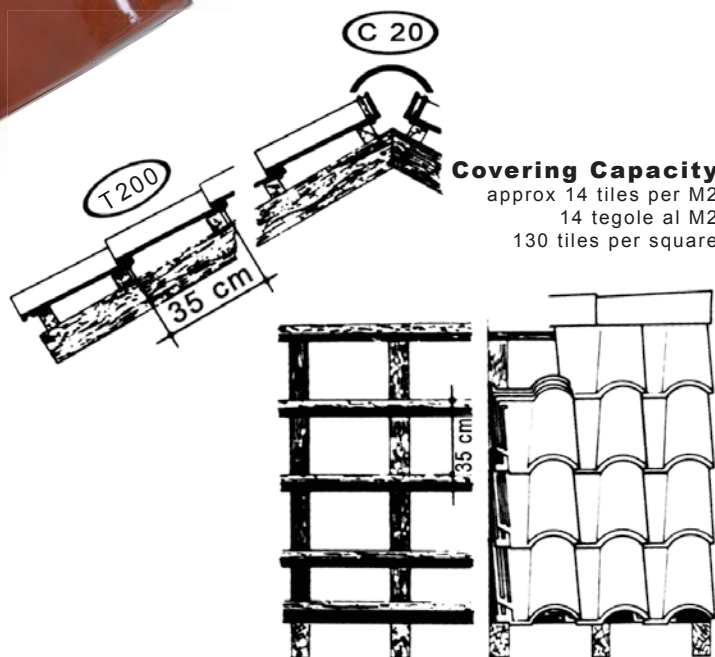



GLAZED "FLAT - PIANA"

TYPE: **T. 400 FLAT**

Outward sizes, dimensioni esterne, dimensions	cm. 41 x 25
Quantity per sqm, quantità per mq, pieces par m2	N° 14
Weight each, peso caduno, poids	Kg. 2,700
Pieces in each box, pezzi per scatola pieces par boîte	N° 8
Pieces in each container, pezzi per container pieces par container	N° 6272



**Covering Capacity**

approx 14 tiles per M2  
14 tegole al M2  
130 tiles per square

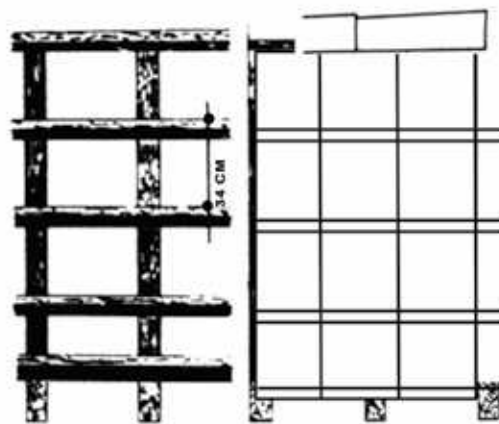
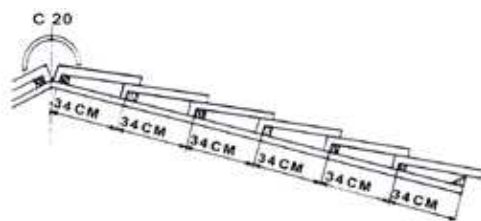

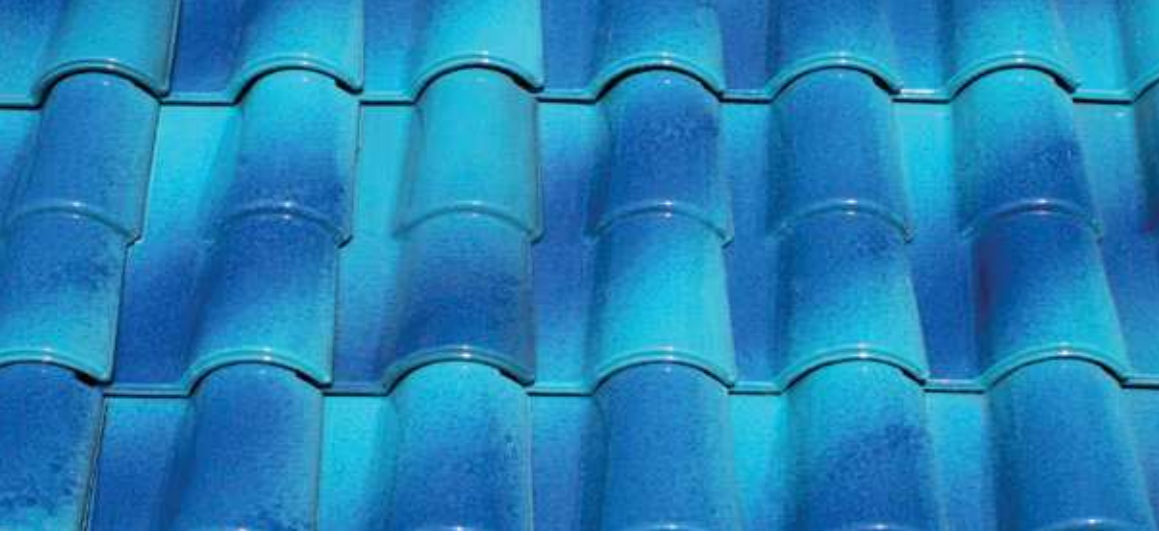



GLAZED "STARLIGHT - DOUBLE COPPO"  
TYPE: **T. 500 Starlight**



Outward sizes, dimensioni esterne, dimensions	cm. 41 x 25
Quantity per sqm, quantità per mq, pieces par m2	N° 14
Weight each, peso caduno, poids	Kg. 2,650
Pieces in each box, pezzi per scatola pieces par boîte	N° 7
Pieces in each container, pezzi per container pieces par container	N° 5488

**Covering Capacity**  
approx 14 tiles per M2  
14 tegole al M2  
130 tiles per square

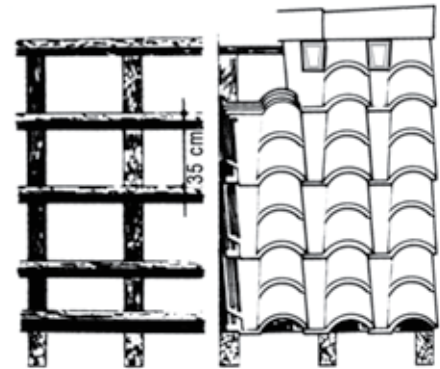
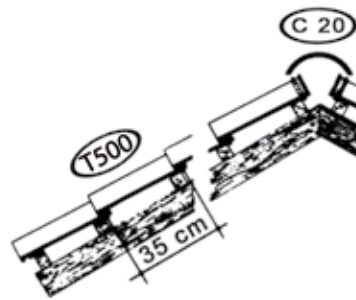

GLAZED "SQUAMA Shingle"

TYPE: **SHINGLE**

Outward sizes, dimensioni esterne, dimensions	cm. 19,6 x 15
Quantity per sqm, quantità per mq, pieces par m2	N° 77
Weight each, peso caduno, poids	Kg. 0,5
Pieces in each box, pezzi per scatola pieces par boîte	N°



GLAZED "SQUAMA Tile"

TYPE: **DOME TILE**

outward sizes, dimensioni esterne, dimensions	cm 150 x 180
quantity per sqm, quantità per mq, pieces per m2	N° 37
weight each, peso ciascuno, poids	gr 640

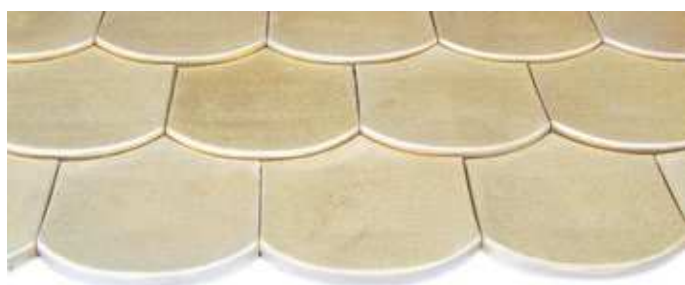
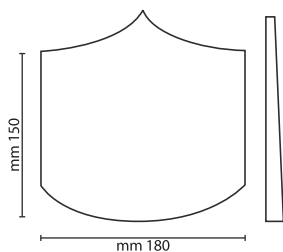

"HISTORICAL V"

TYPE: **HISTORICAL "V"**

Outward sizes, dimensioni esterne, dimensions	cm. 20x11,5 - 22x11
Quantity per sqm, quantità per mq, pieces par m2	N° 50 - 100
Weight each, peso caduno, poids	Kg. 450 - 500
Pieces in each box, pezzi per scatola pieces par boîte	N° 52 - 38
Pieces in each container, pezzi per container pieces par container	N° 40320



GLAZED "COPPO"  
TYPE: **C. 50 Coppo**

Outward sizes, dimensioni esterne, dimensions	cm. 42 x 18
Quantity per sqm, quantità per mq, pieces par m2 (coppo+coppo)	N° 33
Weight each, peso caduno, poids	Kg. 2,300
Pieces in each box, pezzi per scatola pieces par boîte	N° 7
Pieces in each container, pezzi per container pieces par container	N° 5488



GLAZED "ROMANA"  
TYPE: **T. 700 Romana**

Outward sizes, dimensioni esterne, dimensions	cm. 41 x 25
Quantity per sqm, quantità per mq, pieces par m2 (romana+coppo)	N° 10+10
Weight each, peso caduno, poids	Kg. 3,000
Pieces in each box, pezzi per scatola pieces par boîte	N° 7
Pieces in each container, pezzi per container pieces par container	N° 5488

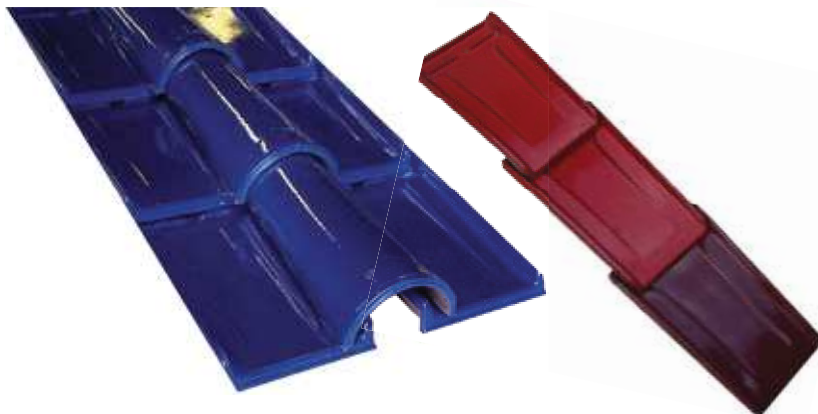

# SPECIAL METALLIC COLOURS

rame-dark gold



bronzo antico-antique bronze



gold glazed - smalto in oro

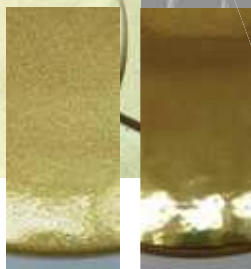

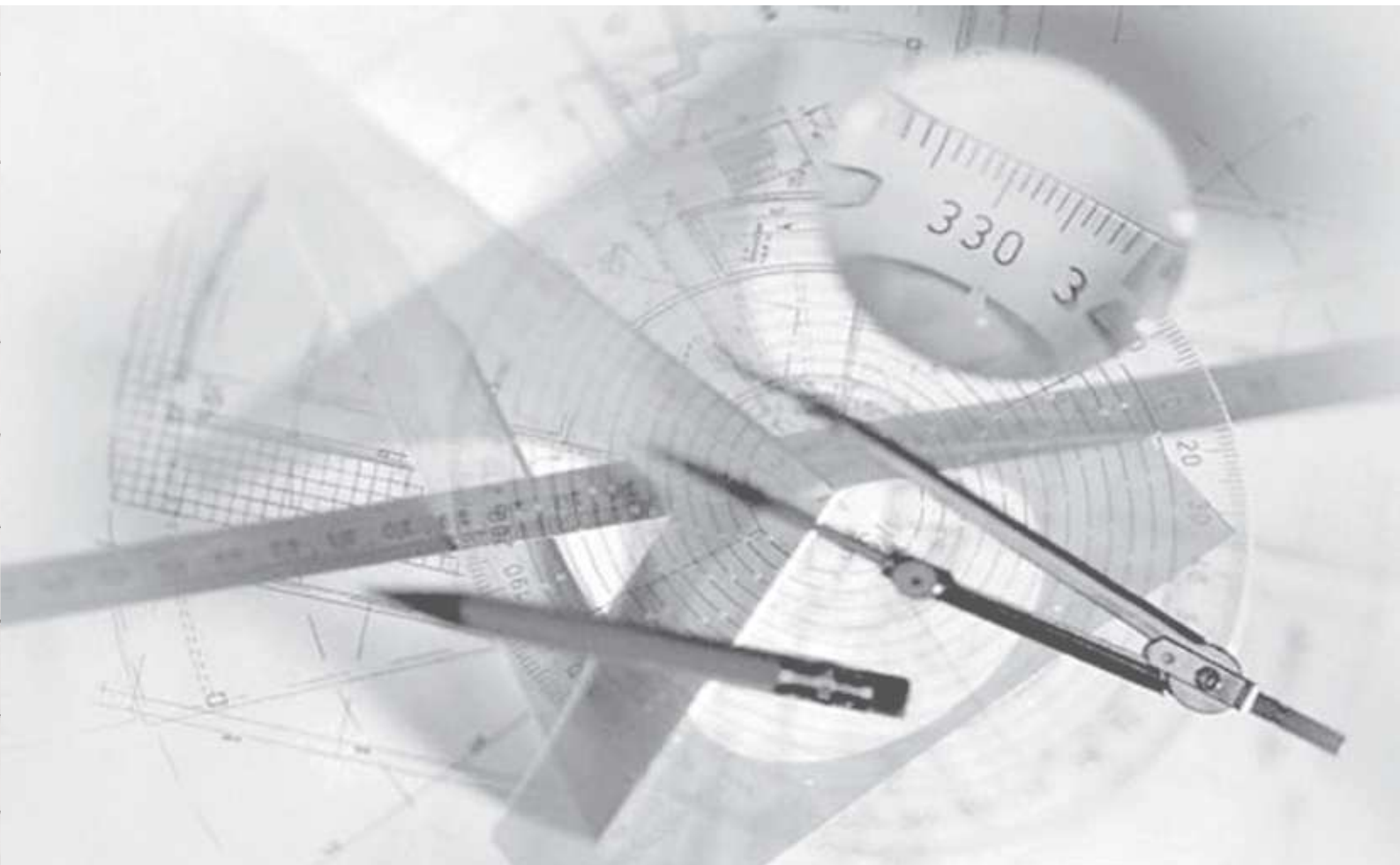

ACCESSORI SPECIAL ITEMS

- 1 C20 colmo - ridge tile
- 2 C30 finale - end ridge tile
- 3 C40 /2/3/4 vie - ways apex
- 4 Laterali - gables
- 5 Doppia Onda - double wave
- 6 Tappo - Cap
- 7 Areatore - Air Vent
- 8 Tegola in vetro - Glass Tile
- 9 Sotto Colmo - Under ridge
- 10 Camino - Chimney
- 11 Parapasseri - Bird Stopper

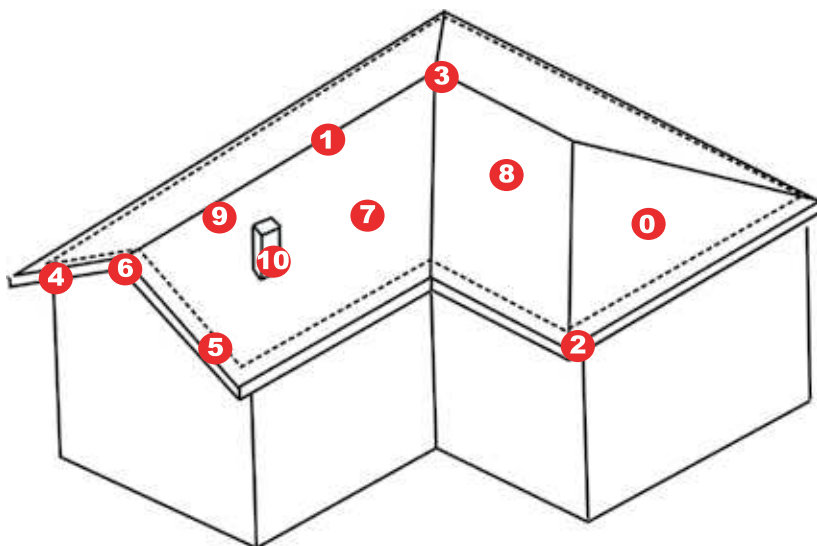

11



1



2



3



10



5

For T300 - T500



9

For T300 - T500



Only T100



Only T300 - T500



Only T200

4



T100



T200



T300 - T500

8



T300



T200



T700



T100



T400

7



6 Only C50

# ventilated roof - tetto ventilato

La formazione di una intercapedine di ventilazione in copertura migliora le caratteristiche termoigrometriche dell'ambiente sottostante, evitando la formazione di condensa in inverno e il caldo eccessivo in estate.

La presenza di una intercapedine di aria favorisce il miglioramento delle condizioni interne perché, in estate, i moti convettivi che si formano, impediscono la formazione della cappa di calore che si crea sotto il manto di copertura, mentre in inverno impediscono il ristagno di umidità che genera col tempo condensa e può causare danni allo strato isolante e alle strutture portanti.

In estate l'aria presente nell'intercapedine si riscalda per effetto delle radiazioni solari. La differenza di temperatura crea delle correnti ascensionali che portano l'aria calda a fuoriuscire dal colmo, mentre quella più fresca entra dalle aperture di gronda.

In inverno, la differenza di temperatura tra interno ed esterno genera la formazione di vapore acqueo che tende ad uscire attraverso l'involucro dell'edificio, determinando l'effetto della condensazione per la presenza di strati di coibentazione. In questo caso la presenza dell'intercapedine ventilata favorisce lo smaltimento del vapore acqueo e migliora la distribuzione del calore interno.

Ventilated and insulated roof make the roof more comfortable and to be able to save energy.

The ventilated and insulated roof is fresh during the summer and warm during the winter which creates an air draught that, from the eaves, goes out through the ridge.

The air that is between the panel and the tiles, because of the sun radiation effect, increases its temperature and, as a consequence of the thermal difference, the warm air goes out through the upper part of the pitch.

Also during the winter, the conditions of the roof are very good for the covering; this is because the condensate that can form is eliminated. In this way, the roof is kept always dry.

With the ventilated roof, it is possible to obtain important characteristics that give the roof longer durability and functionality.

-It permits the disposal of water vapour that provokes condensation.

-It permits to dry little water seepages in case of rain and wind at the same time.



Each piece is wrapped, packed in carton box and protected by removable wax  
tutti i pezzi sono reggettati, scaturati e protetti con strisce di cera

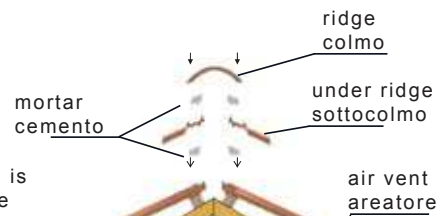

mortar is optional, is possible to use the system (pvc or metal) with screws

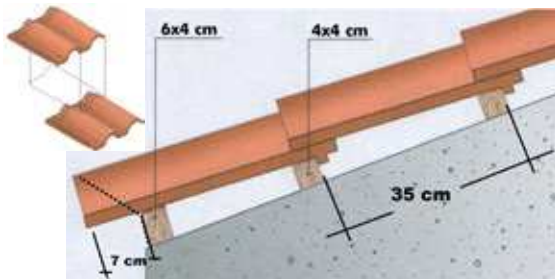
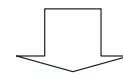



PWD PROJECT-STATAL BUILDING  
UAE

SAUDI BIN LADIN GROUP- MOSCHEA LA MECCA  
MECCA, SAUDI ARABIA

RAHIMTULLAH TRUST TOWER  
NAIROBI, KENYA

MOSCHEA MEDINA  
MEDINA, SAUDI ARABIA

HOTEL METROPOLITAN  
DUBAI, UAE

123 VILLE CLUB LES PINES- GOVERNO  
ALGERI, ALGERIA

HOTEL EXCELSIOR  
ISCHIA, ITALIA

UNIVERSITA'  
MALTA

LOTTIZZAZIONE RESIDENZIALE  
BISCEGLIE, ITALIA

MUSEO NAVALE  
TERENGGANU, MALESIA

COMPLESSO UNIVERSITARIO/SCOLASTICO  
SINGAPORE

EDIFICI GOVERNATIVI  
BRUNEI

RIPRODUZIONE ANTICHE COPERTURE PER  
RISTRUTTURAZIONE CENTRI STORICI  
SINGAPORE

HYATT REGENCY HOTEL  
SHARM EL SHEIKH

LUNGOMARE  
ALESSANDRIA D'EGITTO

SCUDERIE/IPPODROMO  
DUBAI

RESIDENZE PRESIDENZIALI  
KUWAIT

RESIDENZE GOVERNATIVE  
COSTA D'AVORIO

PALAZZO PRESIDENZIALE  
BAGHDAD, IRAQ

RISTRUTTURAZIONE ALBERGO EX FIRENZE NOVA  
FIRENZE ITALIA

MOWEMPICK HOTEL  
DUBAI

THE PEARL PROJECT  
QATAR

G.E.L. PROJECT  
SHANGHAI

WELFARE BUILDING  
LIBREVILLE









**CEIPO**  
  
made in Italy

**CEIPO CERAMICHE srl**

Via Salcini - Montallese

53043 Chiusi ( SIENA )

ITALY

Tel. +39 0578 263141 - 263035

Fax +39 0578 263203

Web: [www.ceipo.it](http://www.ceipo.it)

M@il: [info@ceipo.it](mailto:info@ceipo.it)

